

NMAG

Station for automatic testing night vision devices



Fig. 1. NMAG test station

1 Why is automation needed?

US MIL standards present recommendations for a simple, non-computerized test stations for testing night vision devices. Such recommendations are logical because these standards were created decades ago when computers were not available for metrology applications. Next, there have always been pressure from military users for creations of compact, simple test stations. So far simple, non computerized stations totally dominate market of equipment for testing night vision devices. Therefore Inframet offers a set of simple non computerized stations: NVT, NVS, NV14, NV20.

Nowadays with the improvements of the electronics, computerized test station are becoming the norm. There are many advantages of computerized stations such as ability to record the image, improved accuracy, ease of operation and expanded test capabilities. Therefore Inframet offers also a series of advanced computerized test stations: NIMAX, NICOM, NIVIS.

The computerized stations offer some computer support during measurements but anyway test procedure requires operator of the test station to carry out a long series of important tasks (including subjective measurement of resolution, changing measurement tools, clicking on many buttons in the software). It can be said that a very well trained operator is needed and operation of the computerized station is a difficult and very responsible job. Therefore test speed and accuracy of computerized test station still depends significantly on operator of these stations.

2 What is NMAG?

NMAG station is a new Inframet station that enables almost full automatic testing night vision devices. Operator duties are limited to positioning and focusing of tested NVD and pressing software button to start automatic test procedure. Further on, operator is supported in positioning and focusing of tested NVD by support software that guides the operator in the stages of focusing process to achieve best results. This leads to more accurate tests of NVDs comparing to typical manual/computerized test stations offered by Inframet or other test stations offered on the market. It should be added that NMAG also automatically generates test reports compatible with PN-EN ISO/IEC 17025.

Moreover, improved measurement procedures and new image processing algorithms reduce test time and allow for testing more devices. By limiting human observer role in measurement process, the repeatability and accuracy of measurement is increased.

NMAG improvements do not end on automation. New optical projecting system allow for testing NVDs of larger FOV up to 50° compared to 40° limit in typical test station.

NMAG

Station for automatic testing night vision devices

To summarize, it can be said that all important NVD parameters can be measured using NMAG station. New software offers much simpler measurement procedures and software support during measurement. This leads to improved accuracy, repeatability and faster times per measured device.

KEY FEATURES

- Automatic measurement procedures
- On-site recalibration using CALNOK calibration set
- 14 major NVD parameters can be tested. Binocular parameters included.
- Wider FOV, devices up to 50°
- Illuminance up to 200 lx
- 2856K color temperature light source
- Test reports compatible with PN-EN ISO/IEC 17025.

3 How NMAG stations works?

NMAG test station works as an image projectors that project images of standard targets into direction of tested night vision devices. The latter devices create output image that is later evaluated with help of objective measuring tools (luminance meter, high-res video camera, or digital still camera) combined with test software.

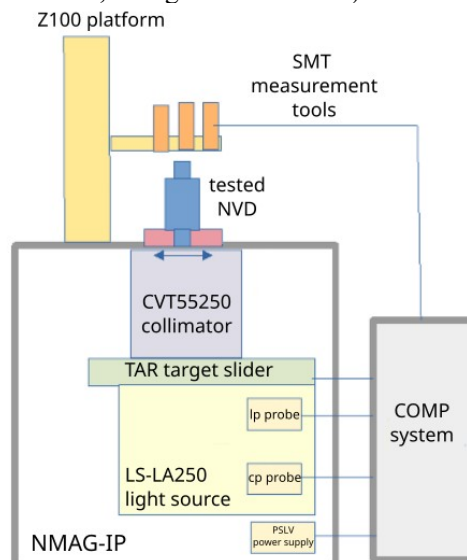

Targets in form of plates with test patterns are position by TAR target slider, illuminated by LS-LA250 light source, projected by CVT collator, captured by tested NVD and evaluated by a SMT measurement tools. Data collected by SMT tools is processed by COMP computer system.

Light source

MIL standards recommend to use a calibrated tungsten filament lamp of 2856K color temperature as a radiation source. It is technically difficult to develop a reliable, long life, 2856K color temperature tungsten filament light source that enables regulation of light intensity in wide range. Therefore typical test stations for testing night vision devices offered on international market are built using a single monochromatic LED light source. Such test stations are calibrated to simulate 2856K color temperature light source for one specific type of night vision device (typically built using Gen 3 tubes and Class A filter). Measurement accuracy significantly deteriorate when night vision devices of different type are tested.

NMAG test station is built using more advanced concept. The station is built using two light sources that can work in two modes: a) halogen bulb of 2856K color temperature source and b) monochromatic LED light source. Halogen source is used during measurement of photometric parameters; monochromatic LED source during measurement of imaging parameters. Therefore NMAG station enables accurate measurement of photometric parameters (like

NMAG

Station for automatic testing night vision devices

brightness gain) of all types of night vision devices. NMAG can be checked and re-calibrated by advanced photometric laboratories in many countries because these stations use classical photometric light source. At the same time life time of the test station was significantly extended due to use of halogen source only for measurement of photometric parameters.

4 What can be tested?

Two types of NVDs can be tested with NMAG test station:

1. Monoculars/Goggles, magnification 1x, FOV up to 50°
2. Sights/Binoculars, magnification up to 4x, FOV up to 10°

5 Recalibration

Typical recalibration period is 2 years. NMAG can be recalibrated on-site using CALNOK calibration kit. There is no need to send station back to check crucial parameters.

6 Comparison to NICOM/NIMAX test station

NMAG has many advantages over typical computerized NICOM/Nimax test stations. The most important ones are:

1. Automation of resolution measurements. NMAG offers alternative to classical resolution measurement based on observer looking at the target. NMAG can predict the classical measurement results using objective parameters such as MTF and FPN.
2. Improved focusing. Operator has software guidance during focusing stage.
3. Improved measurement procedures – No need to switch between measurement modules to measure different parameters from the same image.
4. Full electronic control of light source – NMAG no longer uses knobs and switches to set light levels. It is now fully operated by software. This also speeds up measurements as software knows light levels for a given parameter.

7 Test capabilities

NMAG test station enables measurement (or checking) following parameters:

No.	Parameter	Range	Expanded relative uncertainty
1	Center resolution	0,25 – 7,2 lp/mrad	6%
2	High level resolution	0,25 – 7,2 lp/mrad	6%
3	MTF	in range 0 - 2,5lp/mrad (in case of sights, the range should be multiplied by magnification of tested NVD)	$\leq 0,01$ for MTF > 0,8 $\leq 0,02$ in range: 0,2 < MTF < 0,8 $\leq 0,03$ at < 0,2
4	Minimal Resolvable Contrast	0,25 – 7,2 lp/mrad	6%
5	SNR	1-40	10%
6	Blemishes	From 0.05 to 0.5 mm at screen plane of IITs	15% for spots diameter 75 μ m – 150 μ m 10% for spots diameter 151 μ m – 500 μ m
7	Brightness gain	100-10000 lm/lm	10%
8	Field of view	3°-50°	2%
9	Collimation error	from -1° to +1°	3°
10	Gain disparity	N/A	14%
11	Magnification,	1 to 4x	2%

NMAG

Station for automatic testing night vision devices

12	FPN	Multi-Multi Pattern Noise	0% - 20%	10%
		Multi-Boundary Pattern Noise	0% - 30%	10%
13	EBI		0,02-2 ulx	10%
14	Power consumption,		4-200 mA	1mA or 2%

NMAG test station enables recording of test results and video recording of images generated by tested night vision devices. Special software that enables presentation of recorded videos from several tested NVDs at the same time at PC screen is a part of NMAG test station.

8 SPECIFICATIONS

General	
Modules	NMAG base module w with NMAG-IP projector, ILM3C luminance meter, set of exchangeable adapters, PS1 power supply, OB12 beam combiner, NVC3 high-res video camera, NDC3 digital camera, PC, TAS-AN computer program, NV Display computer program
Light source	
Light Sources	Set of light sources working in two modes: 1) 2856K color temperature polychromatic source, 2) 660nm monochromatic light source
Halogen light source	
Illuminance range of light sources	1 mlx
Regulation type	fixed
Regulation stability	better than 2% of the set value
LED light source	
Illuminance range of light sources	from at least $2 \cdot 10^{-5}$ lx to 200 lx
Regulation resolution	10 μ lx (at low intensity range)
Regulation type	continuous (any value can be set within the regulation range)
Regulation mechanism	manual
Regulation stability	better than 2% of the set value
NMAG-IP projector	
Aperture of built in collimator	55mm
Collimator resolution	> 50 lp/mrad
Type of NVD adapter	Self-centering holders for different types of NVDs
Targets	set of exchangeable targets
ILM3C luminance meter	
Spectral range	similar to human eye
Standard sensitivity mode	
Measurement range	0.05 cd/m ² – 1000 cd/m ²

NMAG

Station for automatic testing night vision devices

Resolution	<0.005 cd/m ²
Measurement uncertainty	<5%
High sensitivity mode	
Measurement range:	10 ucd/m ² – 100 mcd/m ²
Resolution	<5 ucd/m ²
Measurement uncertainty	<7%
NVC3 camera	
Type	CMOS
FOV	4° x 3,1°
Resolution	1280 x 958 px
NDC3 camera	
Type	CMOS
FOV	56° x 56°
Resolution	2748 x 2748 px
General parameters	
Power	230 -110 VAC 50/60 Hz
Operating temperature	5°C to 40°C
Units	Metric (US – option)
Mass	150 kg
Dimensions	1350×590×750mm

*specifications are subject to change without prior notice

9 Market situation

NMAG represent a new generation of systems for testing night vision devices. There is no similar test systems at international market. This new system improves position of Inframet as a world leader in field of apparatus for testing NVDs.

Version 2.3

CONTACT:

Tel: +48 22 666 8780

Fax: +48 22 3987244

Email: info@inframet.com

● **INFRAMET**